

Model ID	Part Number
MZ-7KM1T90	MZ7KM1T9HAJM-00005
MZ-7KM9600	MZ7KM960HAHP-00005
MZ-7KM4800	MZ7KM480HAHP-00005
MZ-7KM2400	MZ7KM240HAGR-00005
MZ-7KM1200	MZ7KM120HAFD-00005

2.5" SATA SSD SM863

(NAND based Solid State Drive)

datasheet

SAMSUNG ELECTRONICS RESERVES THE RIGHT TO CHANGE PRODUCTS, INFORMATION AND SPECIFICATIONS WITHOUT NOTICE.

Products and specifications discussed herein are for reference purposes only. All information discussed herein is provided on an "AS IS" basis, without warranties of any kind.

This document and all information discussed herein remain the sole and exclusive property of Samsung Electronics. No license of any patent, copyright, mask work, trademark or any other intellectual property right is granted by one party to the other party under this document, by implication, estoppel or otherwise.

Samsung products are not intended for use in life support, critical care, medical, safety equipment, or similar applications where product failure could result in loss of life or personal or physical harm, or any military or defense application, or any governmental procurement to which special terms or provisions may apply.

For updates or additional information about Samsung products, contact your nearest Samsung office.

All brand names, trademarks and registered trademarks belong to their respective owners.

© 2015 Samsung Electronics Co., Ltd. All rights reserved.

Revision History

<u>Revision No.</u>	<u>History</u>	<u>Draft Date</u>	<u>Remark</u>	<u>Editor</u>	<u>Review by</u>
0.0	1. Engineering Sample.	Feb. 05. 2015		S.J. OH	J.H. Son
0.5	1. Initial Release.	Feb. 27. 2015		S.J. OH	J.H. Son
1.0	1. Update performance data 2. Update SMART attribute ID 3. Update Identify device data	Apr. 14. 2015	Final	H.I. Choi	J.H. Park
1.1	1. Model ID	May. 20. 2015	Revision	Booyong Park	

Table Of Contents

1.0 General Description	4
2.0 Mechanical Specification	5
3.0 Product Specifications	6
3.1 System Interface and Configuration	6
3.2 System Performance	6
3.3 Drive Capacity	6
3.4 Operating Voltage	6
3.5 System Power Consumption	7
3.6 System Reliability	7
3.7 Environmental Specifications	7
3.8 IOPS Consistency	7
3.9 Latency	8
3.10 Quality of Service (QoS)	8
4.0 Electrical Interface Specification	9
4.1 Serial ATA Interface Connector	9
4.2 Pin Assignments	10
5.0 Command Descriptions	11
5.1 Supported ATA Commands	11
5.2 Individual Attribute Data Structure	12
6.0 SPOR Specification (Sudden Power Off and Recovery)	14
6.1 Data Recovery in Sudden Power Off	14
6.2 Time to Ready Sequence	14
7.0 Product Compliance	15
8.0 Identify Device Data	16
9.0 Ordering Information	18
9.1 Product Line up	18

1.0 General Description

Model ID	Part Number	Capacity ¹⁾
MZ-7KM1T90	MZ7KM1T9HAJM-00005	1.92TB
MZ-7KM9600	MZ7KM960HAHP-00005	960GB
MZ-7KM4800	MZ7KM480HAHP-00005	480GB
MZ-7KM2400	MZ7KM240HAGR-00005	240GB
MZ-7KM1200	MZ7KM120HAFD-00005	120GB

FEATURES

- High-Speed 8 Channel 8 Way Architecture
- Triple 500MHz Cortex-R Core
- V2 MLC NAND Flash Memory
- Up to 2GB LPDDR3 DRAM Buffer Memory
- Serial ATA 6.0Gbps Interface
- Fully complies with Serial ATA 3.0 Standard
- ATA Security Mode feature set
- ATA Host Protected Area feature set
- Support NCQ (Up to 32 depth) Command Set
- Support TRIM Command
- Asynchronous Signal Recovery
- End-to-End Data Protection
- AES 256-bit Encryption
- RoHS Compliant

DRIVE CONFIGURATION

- Form Factor 2.5"
- Interface Serial ATA 6.0 Gbps
- Buffer DRAM Size 512 Megabytes
- Bytes per Sector 512 Bytes

PERFORMANCE SPECIFICATIONS²⁾

- Data Transfer Rate
 - Sequential Read (128KB) Up to 520 MB/s
 - Sequential Write (128KB) Up to 485 MB/s
 - Random Read (4KB) Up to 97 KIOPS
 - Random Write (4KB) Up to 29 KIOPS
- IOPS Consistency (Read/Write @4KB) 99% / 97%
- Average Latency (Read/Write @4KB, QD32 Avg.) 100 us / 35 us
- Quality of Service(99.99%)
 - Read (4KB, QD=1) 0.14 ms
 - Write (4KB, QD=1) 0.12 ms
 - Read (4KB, QD=32) 0.7 ms
 - Write (4KB, QD=32) 2.8 ms

RELIABILITY SPECIFICATIONS

- Non-recoverable Read Error 1 sector per 10¹⁷ bits read
- MTBF 2,000,000 hours
- TBW
 - 1920GB: 12320 TB
 - 960GB: 6160 TB
 - 480GB: 3080 TB
 - 240GB: 1540 TB
 - 120GB: 770 TB

NOTE: 1. TBW is measured while running 100 % random 4 KB writes across the entire SSD.

ENVIRONMENTAL SPECIFICATIONS

- Temperature
 - Operating³⁾ 0 ~ 70 °C
 - Non-operating -40 ~ 85 °C
- Humidity (on-condensing)
 - Non-operating 5 ~ 95 %
- Linear Shock (1/2 sine pulse)
 - Non-operating, 0.5ms 1,500 G
- Vibration (20min /axis on 3 axes)
 - Non-operating (10 ~ 2,000 Hz, Sweep Sine) 20 G

POWER REQUIREMENTS

- Supply Voltage +5V ± 5%
- Voltage Ripple/Noise (Max.) 100 mV p-p
- Active⁴⁾ (Read) 2.4 W RMS
- Active (Write) 3.1 W RMS
- Idle⁵⁾ (Typical) 1.3 W

PHYSICAL DIMENSION

- Width 100.20 ± 0.25 mm
- Depth 69.85 ± 0.25 mm
- Height 6.80 ± 0.20 mm
- Weight Up to 60 g

NOTE: Specifications are subject to change without notice.

1) 1MB = 1,000,000 Bytes, 1GB = 1,000,000,000 Bytes, Unformatted Capacity. User accessible capacity may vary depending on operating environment and formatting.

2) Performance measured using IOMeter 2006 with queue depth 32. Measurements are performed on whole LBA range. Write cache enabled. Performance vary depending on capacity

3) Tc : Case Temperature

4) Active Read power is measured on 4 KB random read with 1920 GB density. Active Write power is measured on 128 KB sequential write with 1920 GB density.

5) Idle power is measured on 1920 GB density with DIPM off.

2.0 Mechanical Specification

[Table 1] Physical Dimensions and Weight

Model	Height (mm)	Width (mm)	Length (mm)	Weight (gram)
120 / 240 / 480 / 960 / 1,920 GB	6.80 ± 0.20	69.85 ± 0.25	100.20 ± 0.25	60 g

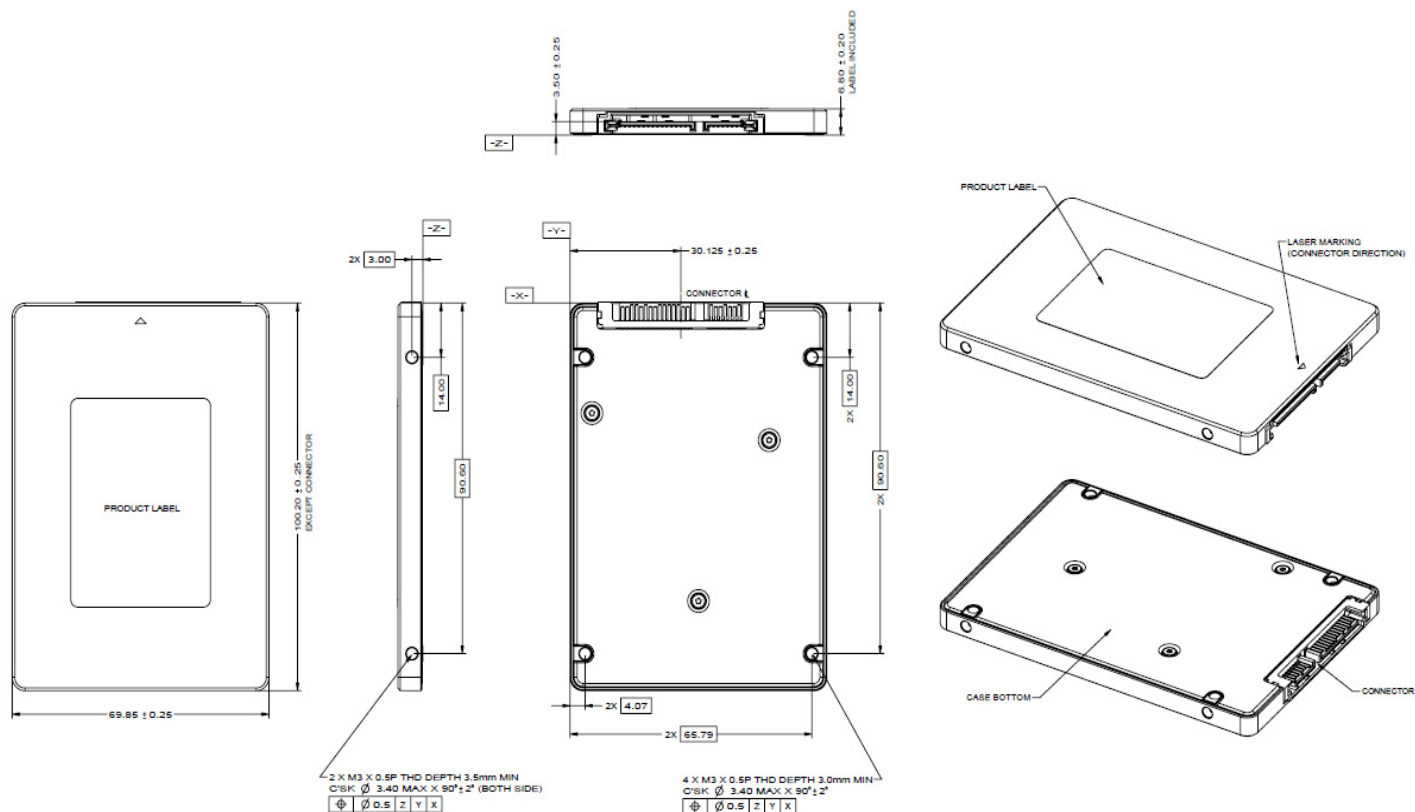

Figure 1. Physical Dimension

3.0 Product Specifications

3.1 System Interface and Configuration

- Burst read / write rate is 600 MB/sec (6 Gb/s)
- Fully compatible with ATA/ATAPI-7 Standard
- Compatible with ATA/ATAPI-8 Mandatory Command

3.2 System Performance

[Table 2] Sequential Read / Write and Sustained Random Read / Write Performance¹

Read / Write	120 GB	240 GB	480 GB	960 GB	1,920 GB
Sequential Read Sector (128 KB)	500 MB/s	520 MB/s	520 MB/s	520 MB/s	520 MB/s
Sequential Write Sector (128 KB)	460 MB/s	485MB/s	485 MB/s	485 MB/s	485 MB/s
Random Read IOPS (8 KB)	57K IOPS	57K IOPS	57K IOPS	57K IOPS	57K IOPS
Random Write IOPS (8 KB)	6K IOPS	10K IOPS	13K IOPS	14K IOPS	14K IOPS
Random Read IOPS (4 KB)	97K IOPS	97K IOPS	97K IOPS	97K IOPS	97K IOPS
Random Write IOPS (4 KB)	12K IOPS	20K IOPS	26K IOPS	28K IOPS	29K IOPS

NOTE:

1. Actual performance may vary depending on use conditions and environment.
- 1) Performance measured using IOMeter 2006 with queue depth 32, C216 Intel SATA 6G port.
- 2) Measurements are performed on whole LBA range.
- 3) Write cache enabled.
- 4) 1 MB/sec = 1,048,576 bytes/sec was used in sequential performance.

3.3 Drive Capacity

[Table 3] User Capacity and Addressable Sectors^{1, 2}

	120 GB	240 GB	480 GB	960 GB	1,920 GB
User-Addressable Sectors	234,441,648	468,862,128	937,703,088	1,875,385,008	3,750,748,848
Bytes per Sector	512 Bytes				

NOTE:

1. Megabyte (MB) = 1 Million bytes; 1 Gigabyte (GB) = 1 Billion bytes
2. Actual usable capacity may be less (due to formatting, partitioning, operating system, applications or otherwise).

3.4 Operating Voltage

[Table 4] Operating Voltage

Item	Requirements
Allowable voltage	5.0 V \pm 5%
Allowable noise / ripple	100 mV p-p or less
Inrush Current ¹	1.0A, <1sec

NOTE:

1. The measurement value of inrush current is also compatible with the standard specification of "Enterprise SSD Form Factor Version 1.0a" released by SSD Form Factor Working Group.

3.5 System Power Consumption

[Table 5] Power Consumption

Read/Write	120 GB	240 GB	480 GB	960 GB	1,920 GB
Active Write ¹ - RMS Average	2.5 Watt	2.7 Watt	2.8 Watt	2.9 Watt	3.1 Watt
Active Read ² - RMS Average	2.2 Watt	2.2 Watt	2.2 Watt	2.2 Watt	2.4 Watt
Idle ³	1.3 Watt	1.3 Watt	1.3 Watt	1.3 Watt	1.3 Watt

NOTE:

1. Active Write power is measured on 128 KB sequential write.
2. Active Read power is measured on 4 KB random read.
3. Idle power is measured with DIPM off.

3.6 System Reliability

[Table 6] TBW, MTBF, UBER Specifications

	120 GB	240 GB	480 GB	960 GB	1,920 GB
TBW ¹	770 TB	1540 TB	3080 TB	6160 TB	12320 TB
MTBF ²	2,000,000 Hours				
UBER ³	1 sector per 10 ¹⁷ bits read				
Data Retention ⁴	3months				
DWPD ⁵	3.6 (5years)				

NOTE:

1. TBW is measured while running 100 % random 4 KB writes across the entire SSD.
2. MTBF is Mean Time Between Failure. As same word, annual failure ratio is 0.438%.
3. Uncorrectable Bit Error Rate (UBER) is a metric for the rate of occurrence of data errors, equal to the number of data errors per bits read as specified in the JESD218 document of JEDEC standard. For the enterprise application, JEDEC recommends that UBER shall be below 10⁻¹⁶.
4. Data retention was measured by assuming that SSD reaches the maximum rated endurance at 40C in power-off state.
5. DWPD is Drive Write Per Day

3.7 Environmental Specifications

[Table 7] Environmental Specifications

Features	Operating	Non-Operating
Temperature ¹	0 °C to 70 °C	-40 °C to 85 °C
Temperature Gradient	30 °C /Hr	30 °C /Hr
Humidity ²	5 % to 95 %, non-condensing	
Shock ³	1500 G, duration 0.5 ms, Half Sine Wave	
Vibration ⁴	20G, 10 - 2000 Hz, 20 min/axis (X,Y,Z)	

NOTE:

1. Temperature specification is following JEDEC standard; Expressed temperature must be measured right on the case.
2. Humidity is measured in non-condensing.
3. Test condition for shock: 0.5 ms duration with half sine wave
4. Test condition for vibration: 10 Hz to 2,000 Hz, 15 mins/axis on 3 axis

3.8 IOPS Consistency

[Table 8] IOPS Consistency

IOPS Consistency ^{1, 2}	120 GB	240 GB	480 GB	960 GB	1,920 GB
Random Read (4 KB)	99%	99%	99%	99%	99%
Random Write (4 KB)	93%	97%	97%	97%	97%

NOTE:

1. IOPS consistency measured using FIO with queue depth 32.
2. IOPS Consistency (%) = (99.9% IOPS) / (Average IOPS) x 100

3.9 Latency

[Table 9] Latency

Latency ¹	120 GB	240 GB	480 GB	960 GB	1,920 GB
Read (4 KB)	100us	100us	100us	100us	100us
Write (4 KB)	66us	38us	35us	35us	35us

NOTE:

1. Latency is measured using FIO with queue depth 1 on 4KB random and write.

3.10 Quality of Service (QoS)

[Table 10] Quality of Service (QoS)

Quality of Service (99%) ^{1, 2}	120 GB	240 GB	480 GB	960 GB	1,920 GB
Read (4 KB, QD=1)	0.12ms	0.12ms	0.12ms	0.12ms	0.12ms
Write (4 KB, QD=1)	0.12ms	0.12ms	0.12ms	0.12ms	0.12ms
Read (4 KB, QD=32)	0.7ms	0.5ms	0.5ms	0.5ms	0.5ms
Write (4 KB, QD=32)	2.9ms	2.7ms	2.5ms	2.4ms	2.3ms
Quality of Service (99.99 %) ^{1, 2}	120 GB	240 GB	480 GB	960 GB	1,920 GB
Read (4 KB, QD=1)	0.12ms	0.14ms	0.14ms	0.14ms	0.14ms
Write (4 KB, QD=1)	0.12ms	0.12ms	0.12ms	0.12ms	0.12ms
Read (4 KB, QD=32)	1.0ms	0.7ms	0.7ms	0.7ms	0.7ms
Write (4 KB, QD=32)	3.8ms	2.8ms	2.8ms	2.8ms	2.8ms

NOTE:

1. QoS is measured using Fio 2.1.3 (99 and 99.99%) in Linux RHEL 6.5 (Kernel 2.6.32) with queue depth 1, 32 on 4KB random read and write.

2. QoS is measured as the maximum round-trip time taken for 99 and 99.99% of commands to host.

4.0 Electrical Interface Specification

4.1 Serial ATA Interface Connector

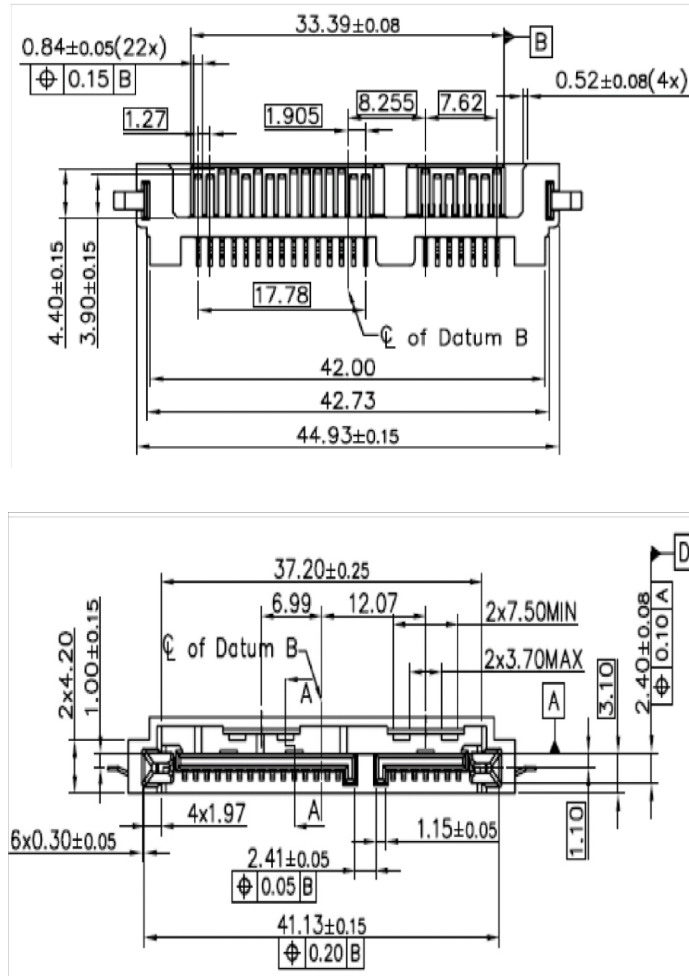

Figure 2. Layout of Drive Connector: AMPHENOL, SATA-001-0009-1-TR

4.2 Pin Assignments

[Table 11] Pin Assignments¹

Word	No.	Plug Connector pin definition		
Signal	S1	GND	2 nd mate	
	S2	A +	Differential signal A from Phy	
	S3	A -		
	S4	GND	2 nd mate	
	S5	B -	Differential signal B from Phy	
	S6	B +		
	S7	GND	2 nd mate	
Key and spacing separate signal and power segments				
Power	P1	V33	3.3 V power (Unused)	
	P2	V33	3.3 V power (Unused)	
	P3	V33	3.3 V power, pre-charge, 2 nd mate (Unused)	
	P4	GND	1 st mate	
	P5	GND	2 nd mate	
	P6	GND	2 nd mate	
	P7	V5	5 V power, pre-charge, 2 nd mate	
	P8	V5	5 V power	
	P9	V5	5 V power	
	P10	GND	2 nd mate	
	P11	DAS / DSS	Device Activity Signal / Disable Staggered Spin-up	
	P12	GND	1 st mate	
	P13	V12	12 V power, pre-charge, 2 nd mate (Unused)	
	P14	V12	12 V power (Unused)	
	P15	V12	12 V power (Unused)	

NOTE:

1. Uses 5 V power only. 3.3 V and 12 V power are not used

5.0 Command Descriptions

5.1 Supported ATA Commands

[Table 12] Supported ATA Commands Summary

Command Name	Command Code (Hex)	Command Name	Command Code (Hex)
CHECK POWER MODE	E5h / 98h	SET MAX ADDRESS EXT	37h
DEVICE CONFIGURATION	B1h	SET MULTIPLE MODE	C6h
DOWNLOAD MICROCODE	92h	SLEEP	E6h / 99h
DOWNLOAD MICROCODE DMA	93h	S.M.A.R.T.	B0h
EXECUTE DEVICE DIAGNOSTIC	90h	STANDBY	E2h / 96h
FLUSH CACHE	E7h	STANDBY IMMEDIATE	E0h / 94h
FLUSH CACHE EXT	EAh	TRIM	06h
IDENTIFY DEVICE	ECh	WRITE BUFFER	E8h
IDLE	E3h / 97h	WRITE BUFFER DMA	EBh
IDLE IMMEDIATE	E1h / 95h	WRITE DMA	CAh
INITIALIZE DEVICE PARMETERS	91h	WRITE DMA (w/o retry)	CBh
NOP	00h	WRITE DMA EXT	35h
READ BUFFER	E4h	WRITE DMA FUA EXT	3Dh
READ BUFFER DMA	E9h	WRITE FPDMA QUEUED	61h
READ DMA	C8h	WRITE LOG DMA EXT	57h
READ DMA (w/o retry)	C9h	WRITE LOG EXT	3Fh
READ DMA EXT	25h	WRITE MULTIPLE	C5h
READ FPDMA QUEUED	60h	WRITE MULTIPLE EXT	39h
READ LOG DMA EXT	47h	WRITE MULTIPLE FUA EXT	CEh
READ LOG EXT	2Fh	WRITE SECTORS	30h
READ MULTIPLE	C4h	WRITE SECTORS (w/o retry)	31h
READ MULTIPLE EXT	29h	WRITE SECTORS EXT	34h
READ NATIVE MAX ADDRESS	27h	WRITE UNCORRECTABLE EXT	45h
READ NATIVE MAX ADDRESS EXT	F8h	Set Date N Time	77h
READ SECTORS	20h		
READ SECTORS (w/o retry)	21h		
READ SECTORS EXT	24h		
READ VERIFY SECTORS	40h		
READ VERIFY SECTORS (w/o retry)	41h		
READ VERIFY SECTORS EXT	42h		
RECALIBRATE	10h		
RECEIVE FPDMA QUEUED	65h		
SANITIZE DEVICE	B4h		
SECURITY DISABLE PASSWORD	F6h		
SECURITY ERASE PREPARE	F3h		
SECURITY ERASE UNIT	F4h		
SECURITY FREEZE LOCK	F5h		
SECURITY SET PASSWORD	F1h		
SECURITY UNLOCK	F2h		
SEEK	70h		
SEND FPDMA QUEUED	64h		
SET FEATURES	EFh		
SET MAX ADDRESS	F9h		

5.2 Individual Attribute Data Structure

The following defines the 12 bytes that make up the information for each Attribute entry in the Device Attribute Data Structure.

[Table 13] Attribute Entry in Device Attribute Data Structure

Byte	Descriptions
0	Attribute ID number 01-FFh
1 - 2	Status flag bit 0 (pre-failure / advisory bit) bit 0 = 0: If attribute value is less than the threshold, the drive is in advisory condition. Product life period may expired. bit 0 = 1: If attribute value is less than the threshold, the drive is in pre-failure condition. The drive may have failure. bit 1 (on-line data collection bit) bit 1 = 0: Attribute value will be changed during off-line data collection operation. bit 1 = 1: Attribute value will be changed during normal operation. bit 2 (Performance Attribute bit) bit 3 (Error rate Attribute bit) bit 4 (Event Count Attribute bit) bit 5 (Self-Preserving Attribute bit) bit 6 - 15 Reserved
3	Attribute value 01h - FDh *1 00h, FEh, FFh = Not in use 01h = Minimum value 64h = Initial value Fdh = Maximum value
4	Worst Ever normalized Attribute Value (valid values from 01h - FEh)
5 - 10	Raw Attribute Value Attribute specific raw data (FFFFFFh - reserved as saturated value)
11	Reserved (00h)

*1 For ID = 199 CRC Error Count

The device supports following Attribute ID Numbers.

[Table 14] SMART Attributes¹

ID (Word)	Attribute Name	Status Flag	Threshold (%)
5	Reallocated Sector Count	110011	10
9	Power-on Hours	110010	-
12	Power-on Count	110010	-
177	Wear Leveling Count	010011	5
179	Used Reserved Block Count (total)	010011	10
180	Unused Reserved Block Count (total)	010011	10
181	Program Fail Count (total)	110010	-
182	Erase Fail Count (total)	110010	-
183	Runtime Bad Count (total)	010011	10
184	End to End Error data path Error Count	110011	97
187	Uncorrectable Error Count	110010	-
190	Air Flow Temperature	110010	-
195	ECC Error Rate	011010	-
197	Pending Sector Count	110010	-
199	CRC Error Count	111110	-
202	SSD Mode Status	110011	10
235	Power Recovery Count	010010	-
241	Total LBA Written	110010	-
242	Total LBA Read	110010	-
243	SATA Downshift Control	110010	-
244	Thermal Throttle Status	110010	-
245	Timed Workload Media Wear	110010	-
246	Timed Workload Host Read / Write Ratio	110010	-
247	Timed Workload Timer	110010	-
251	NAND Writes	110010	-

NOTE:

1. Any nonzero value in the Attribute ID Number indicates an active attribute.

6.0 SPOR Specification (Sudden Power Off and Recovery)

6.1 Data Recovery in Sudden Power Off

If power interruption is detected, SSD dumps all cached user data and meta data to NAND Flash. SSD could protect even the user data in DRAM from sudden power off while SSD is used with cache on. Commonly, data is protected all of the operation period.

6.2 Time to Ready Sequence

In normal power-off recovery status, SSD needs less than 3 seconds to reach operating mode where SSD works perfectly with cache-on state. SSD is ready to respond Identify Device command during FTL OPEN. When the sudden power-off occurs, the user data in DRAM will be dumped into to NAND Flash using the stored power in the capacitor. In sudden power-off recovery condition, mapping data will be loaded or the FTL meta data be rebuilt perfectly for initial max. 18 seconds. During this period, Identify Device command is still supported. It is called SPOR (Sudden Power Off and Recovery).

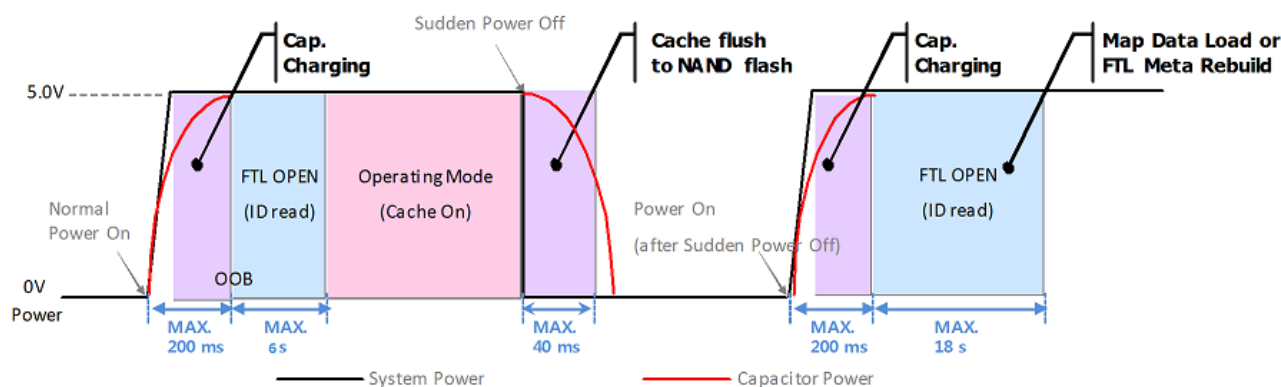

Figure 3. Time to Ready Sequence

[Table 15] Device Ready Time for Normal Read / Write Operation after Sudden Power Off

	120 GB	240 GB	480 GB	960 GB	1,920 GB
Max. Open Time (sec)	6	6	6	9	18

7.0 Product Compliance

[Table 16] Certifications and Declarations

Category	Certification
CE	Comunaute Europeenne
BSMI	Bureau of Standards, Metrology and Inspection
KCC	Korea Communications commission
VCCI	Voluntary Control Council for Interference
C-Tick	Radio Telecommunication Labeling
FCC	Federal Communications Commission
IC	Industry Canada
UL	Underwriters Laboratories, Inc.
TUV	Technischer Uberwachungs Verine e.V
CB	Scheme of the IECEE for Mutual Recognition of Test Certificates for Electrical Equipment



Caution: Any changes or modifications in construction of this device which are not expressly approved by the party responsible for compliance could void the user's authority to operate the equipment.

NOTE:

This equipment has been tested and found to comply with the limits for a Class B digital device, pursuant to part 15 of the FCC Rules. These limits are designed to provide reasonable protection against harmful interference in a residential installation. This equipment generates, uses and can radiate radio frequency energy and, if not installed and used in accordance with the instructions, may cause harmful interference to radio communications. However, there is no guarantee that interference will not occur in a particular installation. If this equipment does cause harmful interference to radio or television reception, which can be determined by turning the equipment off and on, the user is encouraged to try to correct the interference by one or more of the following measures:

- Reorient or relocate the receiving antenna.
- Increase the separation between the equipment and receiver.
- Connect the equipment into an outlet on a circuit different from that to which the receiver is connected.
- Consult the dealer or an experienced radio / TV technician for help.

Modifications not expressly approved by the manufacturer could void the user's authority to operated the equipment under FCC rules.



Industry Canada ICES-003 Compliance Label:

CAN ICES-3 (B)/NMB-3(B)

8.0 Identify Device Data

[Table 17] Identify Device Data

Word	120 GB	240 GB	480 GB	960 GB	1,920 GB	Description
0	0040h	0040h	0040h	0040h	0040h	Obsolete
1	3FFFh	3FFFh	3FFFh	3FFFh	3FFFh	Obsolete
2	C837h	C837h	C837h	C837h	C837h	Obsolete
3	0010h	0010h	0010h	0010h	0010h	Retired
4 - 5	0000h	0000h	0000h	0000h	0000h	Obsolete
6	003Fh	003Fh	003Fh	003Fh	003Fh	Obsolete
7 - 8	0000h	0000h	0000h	0000h	0000h	Reserved for the Compact Flash Association
9	0000h	0000h	0000h	0000h	0000h	Retired
10 - 19	XXXXh	XXXXh	XXXXh	XXXXh	XXXXh	Serial Number (ATA string)
20 - 21	0000h	0000h	0000h	0000h	0000h	Obsolete
22	0000h	0000h	0000h	0000h	0000h	Obsolete
23 - 26	XXXXh	XXXXh	XXXXh	XXXXh	XXXXh	Firmware Revision (ATA string)
27 - 46	XXXXh	XXXXh	XXXXh	XXXXh	XXXXh	Model Number
47	8010h	8010h	8010h	8010h	8010h	Read / Write Multiple Support
48	4000h	4000h	4000h	4000h	4000h	Trusted Computing Feature Set Options
49	2F00h	2F00h	2F00h	2F00h	2F00h	Capabilities
50	4000h	4000h	4000h	4000h	4000h	Capabilities
51 - 52	0200h	0200h	0200h	0200h	0200h	Obsolete
53	0007h	0007h	0007h	0007h	0007h	Obsolete
54	3FFFh	3FFFh	3FFFh	3FFFh	3FFFh	Obsolete
55	0010h	0010h	0010h	0010h	0010h	Obsolete
56	003Fh	003Fh	003Fh	003Fh	003Fh	Obsolete
57	FC10h	FC10h	FC10h	FC10h	FC10h	Obsolete
58	00FBh	00FBh	00FBh	00FBh	00FBh	
59	D110h	D110h	D110h	D110h	D110h	Multiple Logical Setting
60	0DF9h	FFFFh	FFFFh	FFFFh	FFFFh	Obsolete
61	4BB0h	0FFFh	0FFFh	0FFFh	0FFFh	
62	0DF9h	0000h	0000h	0000h	0000h	Obsolete
63	0007h	0007h	0007h	0007h	0007h	Multi-word DMA Transfer
64	0003h	0003h	0003h	0003h	0003h	PIO Transfer Modes Supported
65	0078h	0078h	0078h	0078h	0078h	Minimum Multiword DMA Transfer Cycle Time per Word (ns)
66	0078h	0078h	0078h	0078h	0078h	Manufacturer's Recommended Multiword DMA Cycle Time (ns)
67	0078h	0078h	0078h	0078h	0078h	Minimum PIO Transfer Cycle Time without IORDY Flow Control (ns)
68	0078h	0078h	0078h	0078h	0078h	Minimum PIO Transfer Cycle Time with IORDY Flow Control (ns)
69	4F20h	4F20h	4F20h	4F20h	4F20h	Additional Supported
70 - 74	0000h	0000h	0000h	0000h	0000h	Reserved
75	001Fh	001Fh	001Fh	001Fh	001Fh	Queue Depth
76	850Eh	850Eh	850Eh	850Eh	850Eh	Serial ATA Capabilities
77	0046h	0046h	0046h	0046h	0046h	Serial ATA Additional Capabilities
78	0064h	0064h	0064h	0064h	0064h	Serial ATA Features Supported
79	0060h	0060h	0060h	0060h	0060h	Serial ATA Features Enabled
80	03FCh	03FCh	03FCh	03FCh	03FCh	Major Version Number
81	0039h	0039h	0039h	0039h	0039h	Minor Version Number
82	746Bh	746Bh	746Bh	746Bh	746Bh	Commands and Feature Sets Supported
83	7D01h	7D01h	7D01h	7D01h	7D01h	Commands and Feature Sets Supported
84	4163h	4163h	4163h	4163h	4163h	Commands and Feature Sets Supported or Enabled
85	7469h	7469h	7469h	7469h	7469h	Commands and Feature Sets Supported or Enabled
86	BC01h	BC01h	BC01h	BC01h	BC01h	Commands and Feature Sets Supported or Enabled
87	4163h	4163h	4163h	4163h	4163h	Commands and Feature Sets Supported or Enabled
88	407Fh	407Fh	407Fh	407Fh	407Fh	Ultra DMA Modes
89	0010h	0010h	0010h	0010h	0010h	Normal Security Erase Unit Time
90	0010h	0010h	0010h	0010h	0010h	Enhanced Security Erase Unit Time
91	0000h	0000h	0000h	0000h	0000h	Advanced Power Management Level
92	FFFEh	FFFEh	FFFEh	FFFEh	FFFEh	Master Password Revision Code

MZ7KM1T9HAJM-00005

MZ7KM960HAHP-00005

MZ7KM480HAHP-00005

MZ7KM240HAGR-00005

MZ7KM120HAFD-00005

datasheet

Word	120 GB	240 GB	480 GB	960 GB	1,920 GB	Description
93	0000h	0000h	0000h	0000h	0000h	Hardware Reset Result
94	0000h	0000h	0000h	0000h	0000h	Obsolete
95	0000h	0000h	0000h	0000h	0000h	Stream Minimum Request Size
96	0000h	0000h	0000h	0000h	0000h	Streaming Transfer Time - DMA
97	0000h	0000h	0000h	0000h	0000h	Streaming Access Latency - DMA and PIO
98 - 99	0000h	0000h	0000h	0000h	0000h	Streaming Performance Granularity (DWord)
100 - 103	XXXXh	XXXXh	XXXXh	XXXXh	XXXXh	Total Number of User 48-Bit LBA
104	0000h	0000h	0000h	0000h	0000h	Streaming Transfer Time - PIO
105	0008h	0008h	0008h	0008h	0008h	Maximum Number of 512-byte Data Blocks of LBA Range Entries per DATA SET MANAGEMENT Command
106	4000h	4000h	4000h	4000h	4000h	Physical Sector Size / Logical Sector Size
107	0000h	0000h	0000h	0000h	0000h	Inter-seek Delay for ISO 7779 Standard Acoustic Testing
108	5002h	5002h	5002h	5002h	5002h	World Wide Name
109	538Ch	538Ch	538Ch	538Ch	538Ch	World Wide Name
110 - 111	XXXXh	XXXXh	XXXXh	XXXXh	XXXXh	World Wide Name
112 - 115	0000h	0000h	0000h	0000h	0000h	Reserved
116	0000h	0000h	0000h	0000h	0000h	Reserved for TLC
117 - 118	0000h	0000h	0000h	0000h	0000h	Logical Sector Size (Dword)
119	401Eh	401Eh	401Eh	401Eh	401Eh	Commands and Feature Sets Supported
120	401Ch	401Ch	401Ch	401Ch	401Ch	Commands and Feature Sets Supported or Enabled
121 - 126	0000h	0000h	0000h	0000h	0000h	Reserved for Expanded Supported and Enabled Settings
127	0000h	0000h	0000h	0000h	0000h	Obsolete
128	0021h	0021h	0021h	0021h	0021h	Security Status
129 - 159	0000h	0000h	0000h	0000h	0000h	Vendor Specific
160	0000h	0000h	0000h	0000h	0000h	CFA Power Mode
161 - 167	0000h	0000h	0000h	0000h	0000h	Reserved for the Compact Flash Association
168	0000h	0000h	0000h	0000h	0000h	Device Nominal Form Factor
169	0001h	0001h	0001h	0001h	0001h	DATA SET MANAGEMENT is Supported
170 - 173	2020h	2020h	2020h	2020h	2020h	Additional Product Identifier (ATA string)
174 - 175	0000h	0000h	0000h	0000h	0000h	Reserved
176 - 205	0000h	0000h	0000h	0000h	0000h	Current Media Serial Number
206	003Dh	003Dh	003Dh	003Dh	003Dh	SCT Command Transport
207 - 208	0000h	0000h	0000h	0000h	0000h	Reserved for CE-ATA
209	4000h	4000h	4000h	4000h	4000h	Alignment of Logical Blocks within a Physical Block
210 - 211	0000h	0000h	0000h	0000h	0000h	Write-Read-Verify Sector Count Mode 3
212 - 213	0000h	0000h	0000h	0000h	0000h	Write-Read-Verify Sector Count Mode 2
214	0000h	0000h	0000h	0000h	0000h	Obsolete
215 - 216	0000h	0000h	0000h	0000h	0000h	Obsolete
217	0001h	0001h	0001h	0001h	0001h	Nominal Media Rotation Rate
218	0000h	0000h	0000h	0000h	0000h	Reserved
219	0000h	0000h	0000h	0000h	0000h	Obsolete
220	0000h	0000h	0000h	0000h	0000h	Write Read Verify Mode
221	0000h	0000h	0000h	0000h	0000h	Reserved
222	107Fh	107Fh	107Fh	107Fh	107Fh	Transport Major Version Number
223	0000h	0000h	0000h	0000h	0000h	Transport Minor Version Number
224 - 229	0000h	0000h	0000h	0000h	0000h	Reserved
230 - 233	0000h	0000h	0000h	0000h	0000h	Extended Number of User Addressable Sectors
234	0000h	0000h	0000h	0000h	0000h	Minimum Number of 512-byte Data Blocks per DOWNLOAD MICROCODE Command for Mode 03h
235	0800h	0800h	0800h	0800h	0800h	Maximum Number of 512-byte Data Blocks per DOWNLOAD MICROCODE Command for Mode 03h
236 - 242	0000h	0000h	0000h	0000h	0000h	Reserved
243	0000h	0000h	0000h	0000h	0000h	FDE Security Features
244 - 254	0000h	0000h	0000h	0000h	0000h	Reserved
255	XXA5h	XXA5h	XXA5h	XXA5h	XXA5h	Integrity Word

9.0 Ordering Information

M Z X X X X X X X X X X - X X X X X

1 2 3 4 5 6 7 8 9 10 11 12 13 14 15 16 17 18

1. Memory (M)

2. Module Classification

Z: SSD

3. Form Factor

7: 2.5" 7mmT SATA

4. Line-Up

K: VM, Client/SV(VNAND 2bit MLC)

5. SSD CTRL

M: Mercury

6 - 8. SSD Density

120: 120 GB

240: 240 GB

480: 480 GB

960: 960 GB

1T9: 1,920 GB

9. NAND PKG + NAND Voltage

H: BGA (LF, HF)

10. Flash Generation

A: 2nd Generation

11 - 12. NAND Density

FD: 256G DDP 2CE

GR: 512G QDP 4CE

HP: 1T ODP 8CE

JM: 2T HDP 8CE

13. " - "

14. Default

"0"

15. HW revision

0: No Revision

16. Packing type

0: Bulk

17 - 18. Customer

05: General

9.1 Product Line up

[Table 18] Product Line up

Model ID	Part Number	Density	Type	Remark
MZ-7KM1T90	MZ7KM1T9HAJM-00005	1.92 TB	2.5" SSD	-
MZ-7KM9600	MZ7KM960HAHP-00005	960 GB		
MZ-7KM4800	MZ7KM480HAHP-00005	480 GB		
MZ-7KM2400	MZ7KM240HAGR-00005	240 GB		
MZ-7KM1200	MZ7KM120HAFD-00005	120 GB		